

Hako

Clean ahead

Hako-Citymaster 2000

NEW with
EURO 4-
Engine



For A
Cleaner City.

City
Cleaning

Hako-Citymaster 2000

There's a lot to do in the City.

The Hako Citymaster 2000 provides a convincing solution to suit a wide range of applications. Tailor-made to meet the corresponding requirements. With numerous possibilities of expanding its functionality, for example: winter maintenance.



Hako-Citymaster 2000

The professional solution.

The Hako Citymaster 2000 sets new standards in terms of use and driver comfort. Connectible four-wheel steering, a sweeping width of up to 2,500 mm and a dirt hopper volume up to 1.85 m³ with high dump as well as additional winter maintenance options guarantee that municipal tasks are managed perfectly all year round.

- Excellent visibility of the area being cleaned. Both brushes can be controlled independently of each other, directly from the cockpit. ①
- Water nozzles for dust control on the plate brushes and in the suction mouth. Amount of water can be adjusted from the driver's seat.



- Modern, ergonomically optimized workplace. All operational elements within direct view and reach. ②



- Quiet, two person comfort cabin with excellent all round visibility. Height and rake adjustable steering column. Handball support for fatigue-free operation of the joysticks. ②
- Warm water heating with multistage blower. Optional air conditioning.
- Comfort sprung driver's seat and passenger seat with adjustable backrest fitted as standard. Optional: driver's seat with raised backrest, lumbar support and headrest, sprung passenger seat or air sprung driver's seat.

- As a result of the optional noise insulation package the Citymaster 2000 achieves the level of 99 dB(A) effortlessly and thus fulfils the requirements of the Machine Noise Prevention Regulations (32. BImSchV § 7 etc.)
- The noise insulation package is integrated in the hopper. Despite this, the build height of the Hako-Citymaster 2000 enables it to negotiate entrances of underground car parks or areas with height restricted access without problem.
- According to Guideline 2000/14 EU sweepers are only able to work in noise sensitive areas if these do not exceed a noise level of 99 dB(A). ③
- The Hako Citymaster 2000 already has an integrated, effective and quiet used air outlet to the rear. ④
- High grade steel dirt hopper with optimum filling capacity. Volume 1.85 m³. Emptying is carried out via high dump at a lift height of up to 145 cm and 45 degree tipping angle. ⑤
- Handy: collision protection at the side and front. ⑥

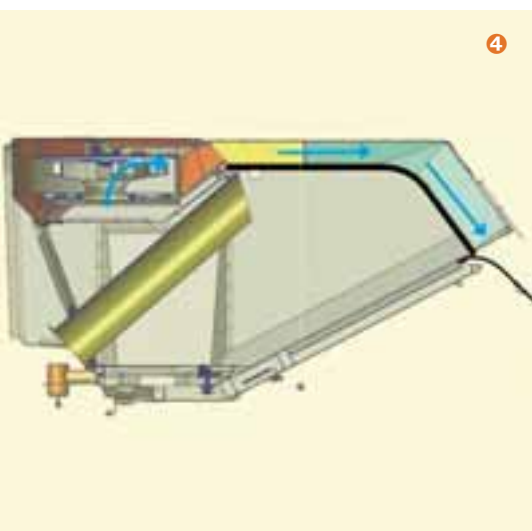

Hako-Citymaster 2000



Fit for the environment...

- The Citymaster 2000 is equipped with an environmentally-friendly 2.0 l industrial engine with integrated soot particulate filter. This soot particulate filter remains maintenance-free over the whole machine life, which means that no additional costs are incurred. The system filters approx. 95% of the soot particles from the used air and thus reduces the share of noxious substances from the exhaust fumes.
- No additives are required, as it is a closed system, which starts the combustion process independently once the max. load level is reached.
- The hand held suction hose (optional) guarantees quick, easy and simple operation. ① It is mounted on the rear hopper door and is integrated in the total height of the vehicle. As a result entrances in underground car parks or height restricted access do not prove to be a problem.



- Thanks to the swinging arm and a length of approx. 3 m it is possible to work on both sides of the vehicle.

- The hand held suction hose has a diameter of 120 mm, whereby sufficient suction power exists for any requirements. After work has finished the suction hose can be packed away again safely and protected against collisions.



- Handy: toolbox as a storage area for the standpipe, C-hose and further small parts at the rear of the vehicle. ②

in winter too.



- The Hako Citymaster 2000 is just as much in its element doing winter maintenance tasks. ① For small winter maintenance jobs a gritter attachment is available for sand, salt and grit. Combined with a front mounted sweeper or various sprung flap snow ploughs/snow shields with a working width up to 170 cm, there is nothing in the way of snow removal and speedy gritting of footpaths and cycle tracks. ②

- For seasonal adaptation to deal with large winter maintenance tasks, a gritter attachment (damp salt or dry gritter) is available for extensive gritting of roads, footpaths and cycle tracks.

- With this expansion of its functions the Hako Citymaster 2000 ensures that areas can be walked and driven upon safely all year round – and not just during the sweeping season. ③





Hako-Citymaster 2000

Technical data.

Engine: Water-cooled large size industrial turbo diesel engine, VW 2.0 l, 74.0 kW, IMO EURO IV CBKA, (100 hp) at 3,000 rpm. With maintenance-free soot particulate filter in a closed system. 4 cylinder 4 stroke engine. Injection pump system, water cooling, working revolutions 1900 - 2200 rpm. Regulation of working revolutions via TIP UP-DOWN switch. Emission levels according to Euro 4. Fuel tank 50 litres.

Drive transmission: Hydrostatic drive with electronic control. 2 drive stages to be switched under load, differential lock (acting on rear axle). Drive control with automatic load regulation in transport and work mode or specified engine revolutions (noise limitation).

Drive performance: Transport mode: 0-50 km/h, working mode 0-15 km/h, reverse transport mode 0-25 km/h, reverse working mode: 0-15 km/h.

Chassis and steering: Welded frame, dropped in the front part and angled, rigid axles guided at longitudinal swinging arms and Panhard rod, helical spring system, additional rubber and hydraulic shock absorbers.

Hydrostatic front wheel steering with connectible four wheel steering, outer turning radius radius of fixed parts: 3500 mm.

Tyres: Standard: 4 wheels on 6J 15 H2 ET 50 rims, tyres: 215/70 R 15 C. Special tyres 255/75 R15 available.

Brakes: Hydraulic dual circuit brake system with servobrake and load-dependent regulation of braking power on front and rear axle. Tandem vacuum servobrake, automatic brake re-adjustment, mechanical parking brake acting on rear axle.

Cabin: 2-seat full comfort cabin in space frame design with air-sprung comfort driver's seat, adjustable to the driver's weight. Ergonomic arrangement of all operational elements. Warm water heating and heated, tinted wrap-around windscreen, made of

safety glass, fitted as standard: large glazed doors with sliding windows and large window in the bottom part; folding wing mirrors adjustable from inside; air conditioning system optional.

Sweeping unit: 1.85 m³ stainless steel tank, hydraulic tilting to 45°, emptying height 1,450 mm. Quick exchange front mounted sweeper unit in view of the driver. Two plate brushes of Ø 900 mm each, hydraulically driven, brush speed and working width adjustable from the driver's seat, side and front collision protection.

Fan: High-performance multi-bladed radial fan, rubber-cushioned and sound-proofed.

Power lift/attachments: Front power lift with 2 double-acting hydraulic cylinders (lifting, lowering, ground pressure) and floating position with quick coupling triangle cat. 1 N. Lifting capacity at coupling triangle 950 daN.

Dimensions and weights:

Length with brushes	mm	4.550
Width	mm	1.300
Height (standard tyres)	mm	1.995
Unladen weight acc. to German StVZO	kg	2.900
Maximum laden weight	kg	4.500
Wheelbase	mm	1.900
Track width	mm	1.033
Ground clearance, overall	mm	150
Maximum sweeping width	mm	2.500
Clean water tank	l	330

We reserve the right to change the shape, colour and design of machines in the interests of continued technical development.



Everything speaks for Hako:



Cleanliness with safety.

Hako machine adhere to strict quality regulations/standards - "Quality made by Hako". We also take care of what we sell - world-wide.



Sales, hire, leasing, rental.

With Hako, you can plan your capital expenditure on a completely individual basis. You can enter into short-term, medium-term or long-term agreements with regard to machine usage.



We are there for you day and night.

Round-the-clock service and express spare parts delivery - order today and have the parts tomorrow! So you can get on again as quickly as possible.



Close to you, wherever you are.

The unsurpassed close knit Hako sales and service network means we are always close at hand - a bonus when you need us. Convince yourself.

Hako
Clean ahead

Hako-Werke GmbH
Hamburger Straße 209-239
D-23843 Bad Oldesloe
Phone: ++49 (45 31) 8 06-0
Fax: ++49 (45 31) 8 06-3 38
e-mail: info@hako.com
www.hako.com

